

Model Number: H26TG-35-06  
Product Line: Peerless Silver

Revision: Rev 1\_0  
Date: 23-May-12



**Product Description:**

This H family tweeter features an 25 mm 6 ohm voice coil, a treated silk dome, a large rear chamber for low resonant frequency, and a ferrofluid-cooled ferrite motor. The large motor and rear chamber allows for robust power handling capacity. The tweeter comes with a faceplate with recessed mounting holes, for easy installation into the desired application. The faceplate has a horn geometry for increased sensitivity.



**Mechanical 2D Drawing:**

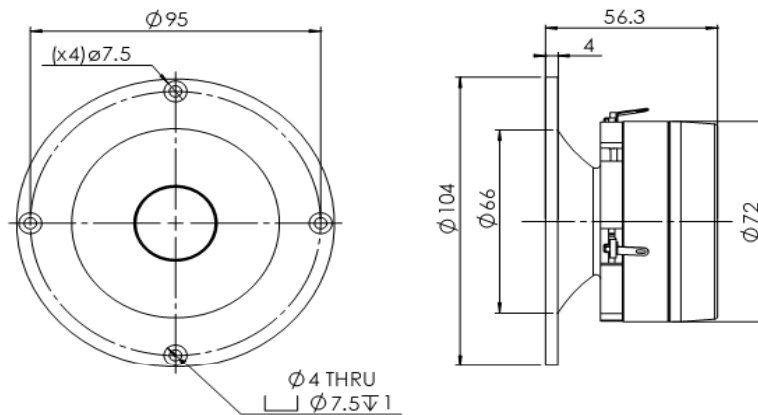

**Specifications:**

DC Resistance	$R_{evc}$	$\Omega$	3.9	$\pm 7.5\%$	Energy Bandwidth Product	EBP	$(1/Q_{es}) \cdot f_s$	1622
Minimum Impedance	$Z_{min}$	$\Omega$	5.9	$\pm 7.5\%$	Moving Mass	$M_{ms}$	g	0.21
Voice Coil Inductance	$L_e$	mH	0.03		Suspension Compliance	$C_{ms}$	um/N	173.8
Resonant Frequency	$f_s$	Hz	832	$\pm 20\%$	Effective Cone Diameter	D	cm	3.0
Mechanical Q Factor	$Q_{ms}$	-	0.6		Effective Piston Area	$S_D$	cm <sup>2</sup>	7.1
Electrical Q Factor	$Q_{es}$	-	0.51		Equivalent Volume	$V_{as}$	L	0.012
Total Q Factor	$Q_{ts}$	-	0.27		Motor Force Factor	BL	T-m	2.88
Ratio $f_s / Q_{ts}$	F	$f_s / Q_{ts}$	3059		Motor Efficiency Factor	$\beta$	$(T \cdot m^2) / \Omega$	2.15
Half Space Sensitivity @ 2.83V	dB@2.83V/1m	dB	94.9	$\pm 1.0^1$	Voice Coil Former Material	VC <sub>m</sub>	-	ASV
Sensitivity @ 1W/1m	1W/1m	dB	91.7	$\pm 1.0^1$	Voice Coil Inner Diameter	VC <sub>d</sub>	mm	25.8
					Gap Height	Gh	mm	2.5
Rated Noise Power (IEC 2685 18.1)	P	W	100		Maximum Linear Excursion	$X_{max}$	mm	0.45
Test Spectrum Bandwidth	2.5KHz-20KHz		12 dB/Oct		Ferrofluid Type	FF	-	APGL11
					Transducer Size	-	-	25 mm
					Transducer Mass	-	Kg	0.52

1 - Piston Band Sensitivity Tolerance

**Frequency and Impedance Response:**

